

BK PRECISION®

Instruction Manual

Model 490B CRT Analyzer - Rejuvenator



Limited one-Year Warranty

B&K Precision Corp. warrants to the original purchaser that its product and the component parts thereof, will be free from defects in workmanship and materials for a period of one years from the data of purchase.

B&K Precision Corp. will, without charge, repair or replace, at its' option, defective product or component parts. Returned product must be accompanied by proof of the purchase date in the form a sales receipt.

To obtain warranty coverage in the U.S.A., this product must be registered by completing and mailing the enclosed warranty card to B&K Precision Corp., 1031 Segovia Circle, Placentia, CA 92870 within fifteen (15) days from proof of purchase.

Exclusions: This warranty does not apply in the event of misuse or abuse of the product or as a result of unauthorized alternations or repairs. It is void if the serial number is alternated, defaced or removed.

B&K Precision Corp. shall not be liable for any consequential damages, including without limitation damages resulting from loss of use. Some states do not allow limitation of incidental or consequential damages, so the above limitation or exclusion may not apply to you.

This warranty gives you specific rights and you may have other rights, which vary from state-to-state.

Model Number: _____

Date Purchased: _____

1031 Segovia Circle
Placentia, CA 92870
714.237.9220
714.237.9214 Facsimile

TABLE OF CONTENTS

1. GENERAL.....	1
1.1 Description.....	1
1.2 Specifications	1
2. INSTALLATION	3
2.1 Power supply	3
3. CONTROL DESCRIPTION.....	4
4. HOW TO USE	8
4.1 Preparation	8
4.2 Use	8
4.3 CRT test	8
5. MAINTENANCE.....	13
5.1 General.....	13
6. SERVICE INFORMATION	13

2. INSTALLATION

2.1 Power supply

This appliance is delivered ready for 110V AC, 50-60 Hz. Before connecting the instrument, be sure the supply voltage is the right one. This equipment can be powered with voltages for 110, 125, 220 and 240V AC, 50-60 Hz.

If the instrument is to be connected to other input voltages the next steps should be followed:

WARNING

BEFORE YOU PERFORM THE FOLLOWING STEPS UNPLUG OFF THE DEVICE.

Remove the 6 fastening screws from the case and pull out the chassis. Once the chassis is removed from the case, change the power transformer plug over to the terminal of the chosen voltage (110-125-220-240V) and replace the fuse if required (see fuse chart below).

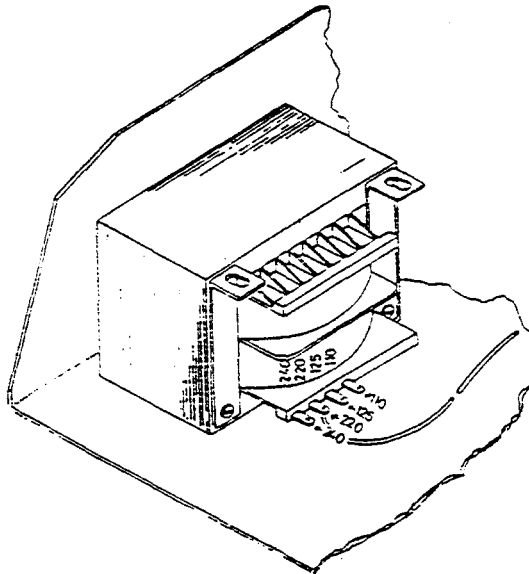

Figure 1.-

FUSE TYPE TO BE: 5 X 20 mm and:

1.0 A FOR 110 125 V

0.5 A FOR 220 240 V

THE INSTRUMENT COULD GET DAMAGED IF THESE INSTRUCTIONS ARE IGNORED.

3. CONTROL DESCRIPTION

Front Panel

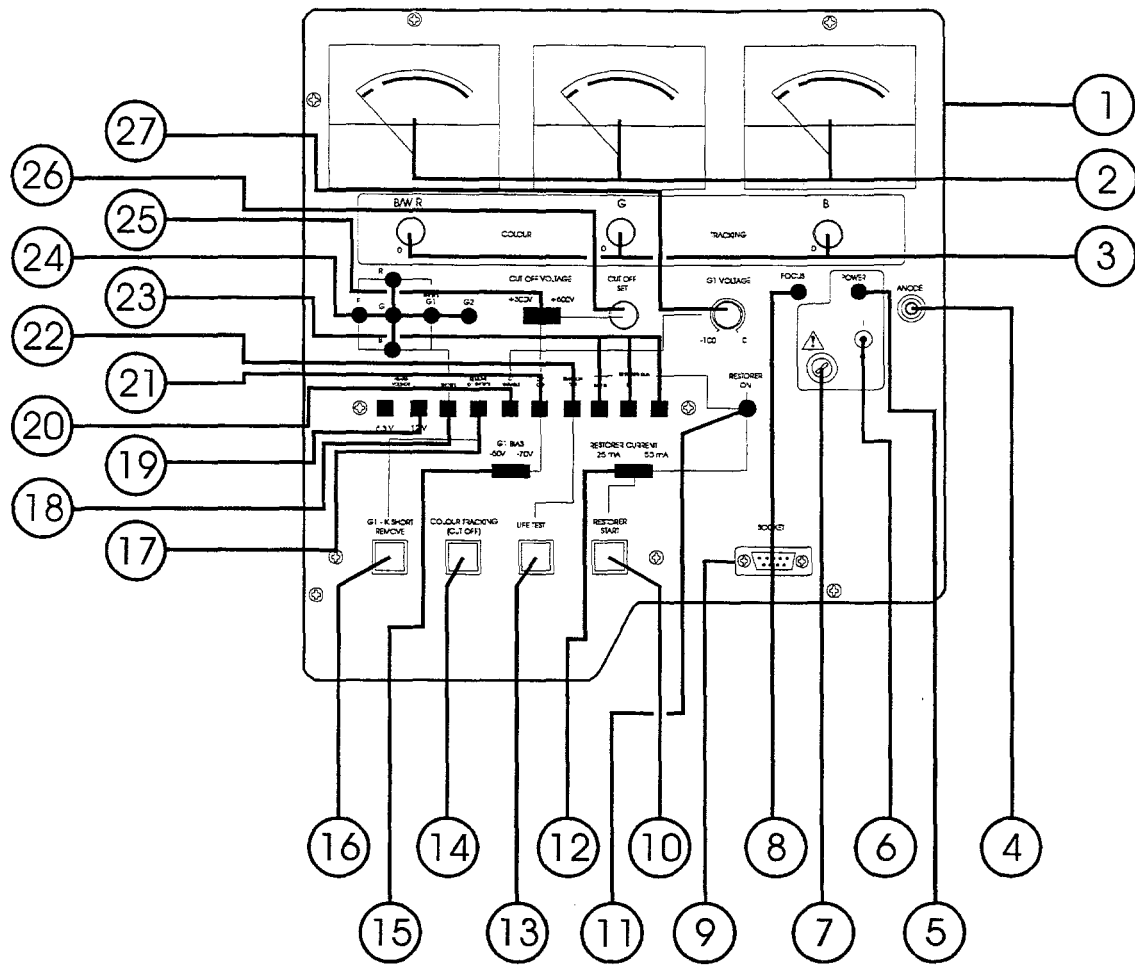

Figure 2.-

- [1] AC input cable
- [2] R, G and B meters

The meters will display current of cathodes in EMISSION TEST [22] function. Color areas enable state of tubes to be known. At RESTORER GUN pointers will move according to the rejuvenating swing.

- [3] The three commands B/W, G and B

Are used to equalize the emitting currents of the tube cathodes.

- [4] The ANODE connector
Used to apply voltage to the tube through the high voltage cable supplied with the instrument.
- [5] POWER indicator
Lights when the instrument is on.
- [6] Main Power Switch
Turns unit on.
- [7] Fuse holder
Protecting the equipment in the event of an overload or short circuit.
- [8] FOCUS indicator
Reports the right switching and operation of the FOCUS.
- [9] SOCKET connector
Connects the adapter cable to the 490B.
- [10] RESTORER START pushbutton
Starts the rejuvenation automatic cycle.
- [11] RESTORER ON indicator
Reports the instrument is performing a rejuvenation.
- [12] RESTORER CURRENT selector
Selects rejuvenating currents from 25 to 50 mA.
- [13] LIFE TEST pushbutton
Tests the tube life in function EMISSION.
- [14] COLOR TRACKING pushbutton
The color tracking is put into function.
- [15] G1 BIAS selector
To bias G1 to $-50V$ or $-70V$ in the CUT-OFF function.

[16] G1 - K SHORT REMOVE pushbutton

Detects leakage and removes shorts, in the REMOVE SHORTS[17] function.

[17] REMOVE SHORTS key

For removing leakage's and shorts between G1 and any cathode and between cathodes and the filament by pushing and releasing pushbutton G1-K SHORT REMOVE [16]. If a short persists, push this key several times.

[18] SHORTS key

Senses leakage's and shorts between the tube electrodes, through following neon indicators [24]:

- F and R, G or B for leakage's or shorts between G1 and cathodes R, G or B.
- G1 for leakage's or shorts between G1 and cathodes R, G or B.
- G1 and G2 for leakage's between electrodes G1 and G2. In each case, two neon lamps will light at once.

[19] HEATER VOLTAGE keys

Used to select the tube filament voltage between 6.3V with a 1A Max, or 12V with a 0.5A maximum current.

[20] G1 VARIABLE key

Through this key G1 variable voltage can be selected. In this way the voltage/current specific curve of the tube can be plotted through the G1 VARIABLE control [27] between -100V and 0V, and beam current indications from the meters[2] readings.

[21] CUT-OFF key

Allows the tube to be set at the cut-off point by turning CUT-OFF SET knob [26] and CUT-OFF switch [25] to +300V or +600V. The G1 BIAS [15] selector is used for biasing the tube with -50V or -70V.

After setting the tube at the cut-off point, the COLOR TRACKING pushbutton [14] is used to perform current balance between cathodes in order to equalize emitting currents through controls B/W, R, G and B [3] within a restricted range.

[22] EMISSION TEST key

Measures the emission current of the three cathodes at the same time at the cut-off point; this means that settings performed previously in function CUT-OFF [21] cannot be modified.

Through LIFE TEST [13] pushbutton variation of cathode currents can be evaluated when lessening the filament voltage. This will give an approximate idea of the expected life of the tube.

[23] RESTORER GUN keys

Keys B/W, R, G or B will select the cathode to be rejuvenated. The selector [12] RESTORER GUN permits two rejuvenating levels to be chosen, either 25 or 50 mA.

RESTORER START pushbutton [10] will give rise to the rejuvenating cycle stated by the LED RESTORER ON [11].

[24] SHORTS indicators

In function SHORTS these light lamps will point out leakage's and shorts between tube electrodes.

[25] CUT-OFF VOLTAGE

Voltage selector of G2 in function CUT-OFF [21].

[26] CUT-OFF SET

Regulates voltage of G2 in function CUT-OFF [21].

[27] G1 VOLTAGE

Regulates the bias of G1 in function VARIABLE [20].

4. HOW TO USE

4.1 Preparation

Before connecting the unit to input voltage, turn all rotating knobs B/W, G, & B [3], CUT-OFF SET [26], and G1 VOLTAGE [27] to the left, release keys REMOVE SHORTS [17] through RESTORER GUN [23] (disabled), and set switches RESTORER CURRENT [12], G1 BIAS [15], and CUT-OFF VOLTAGE [25] to the left hand position. If required, set the mechanical zero of meters.

4.2 Use

1. Plug the 490B into the AC outlet .
2. Select the suitable CRT adapter (see Set-Up Chart) and plug it into the socket adapter cable.
3. Plug the cable into its connector, SOCKET [9].
4. Read the suitable CRT filament voltage (see Set-Up Chart) and push the filament voltage key related with [19].
5. Connect the bias voltage of G1 BIAS through switch [15] at -50V.
6. Select cut-off voltage of G2 CUT-OFF. Set the voltage switch [25] at +300V.
7. Disconnect the TV set or monitor from mains and unload (short to ground) the tubes High Voltage Anode several times if required. (**WARNING:** This HVA uses extremely high voltages and should be handled with extreme caution)
8. Connect the CRT Adapter to the back of the CRT to be restored.
9. Turn unit on with Main Power switch [6]. Power indicator [5] will light and the CRT will heat up.

4.3 CRT test

a. Setting the CUT-OFF

Push key CUT-OFF [21] and slowly turn the CUT-OFF SET control [26]. Watch carefully at pointers of the three meters. As soon as the first pointer reaches the CUT-OFF indication at the scale, stop turning control CUT-OFF SET [26]. Now the cut-off current of the CRT is set. **This setting should not be altered in any other measurements.** In the case the pointers do not reach the CUT-OFF indication at the scale, move Cut-off Voltage switch [25] to the +600V position (far right position).

With black-and-white tubes, watch at the B/W R meter only.

b. Leakage test

Push key SHORTS [18] look whether some leakage or short indicators light [24]. If there are leakage's or shorts, lamps relative to the affected electrodes will light. For instance if F and G are lit, leakage's or shorts are between the filament and the green cathode. Should any indicator [24] light, then push key REMOVE G1 SHORT [17] and then push the G1-F SHORT pushbutton [16]. Now the unit is unloading the capacitance between cathodes and the CRT to eliminate leakage's or shorts.

Next, push SHORTS key [18] to verify whether some indicators light. If so, then repeat the same procedure after waiting at least 10 seconds to let the capacitor charge.

c. Emission test

Push key EMISSION TEST [22]. Pointers will show the emitting value of cathodes. Color picture tubes in accurate state will give current values between nearly 0.8 and 1.6 mA. Black-and-white tubes will give readings from 0.5 to 1 mA. Serviceable tubes with a good rejuvenating result will afford between 0.3 and 0.8 mA (B/W 0.3 to 0.5 mA). Lasting results usually are not achieved when rejuvenating cathodes yielding up below 0.3 mA (B/W 0.2 mA), because they are too exhausted.

In emission mode, lamp FOCUS [8] should light, indicating the proper operation of that electrode.

d. Rejuvenation

These are the procedures how to rejuvenate a CRT:

- 1) Push key Restorer Gun [23] of that cathode to be rejuvenated; the red key for the red cathode, the green key for the green cathode and the blue key for the blue cathode.

Select the rejuvenating current through Restorer Current selector [12]. Begin the rejuvenating process at a 25 mA current only if there is no improvement of the emitting current or the increase is very low, then repeat the rejuvenating process at 50 mA .

Plug the tip of the male connector of the H.V. cable into the female Anode connector [4] at the panel, the other end into the H.V.A. connector of the CRT (**unloaded previously**).

The rejuvenating process will start through pushbutton RESTORER START [10]. The 490B first will heat up the picture tube and then it will start rejuvenation. The rejuvenating process is fully automatic and takes about 70 seconds. The rejuvenating indicator RESTORER ON [11] will be on for all the process time. It goes out when rejuvenation has ended.

Rejuvenating current intensity can be followed at the instrument of the respondent cathode [2], (R, G or B).

When the rejuvenating process is started through RESTORER START [10] pushbutton, it cannot be stopped except by switching the unit off through the POWER [5] switch (this is not recommended unless it is absolutely necessary).

- 2) After a rejuvenation process is fulfilled, it is suitable to make a new measurement of emission in order to verify a likely variation. As a rule the emission value is slightly higher, however in some CRTs it may be alike or a little lower. Still it does not mean the rejuvenating process failed.

The rejuvenating process is likely to be repeated several times when applied to very exhausted tubes. In color tubes it is important that emitting values of the 3 systems (R-G-B) to be nearly the same.

- 3) After rejuvenating color tubes revise the black and gray adjustment and compensate it if needed.
- 4) Cathode tube rejuvenation comments.

In order to decide whether it is worth rejuvenating a CRT, it will be helpful to know conditions in which that tube has been used.

Picture tubes that work from the first day at full intensity (highest contrast and brightness) for long periods of time and have lost brightness will not yield the desirable result even after several rejuvenation's. This is the case for many TV game picture tubes, these tubes may be rejuvenated only in very few cases, because their cathodes are short of barium oxide.

Another event is the one of tubes working in normal conditions in household TV sets (standard contrast and brightness adjustment). In these sets, the cathode losses its emitting capacity due to dirt.

Dirt is caused by fine dust particles left in the glass tube during the manufacture process.

The more dust particles that are depositing on the cathode, the less emission will be supplied the picture may become weak and undefined. These picture tubes may be "repaired" by a rejuvenation that gives a good result, provided that a sufficient mass of barium oxide subsists in the cathode.

e. Life expectance test

The life expectance test can be performed at any time, provided that the CUT-OFF voltage is set.

Push key EMISSION TEST [22]. Meter pointers will state the cathode current value. Record these currents. Now push the EMISSION LIFE TEST pushbutton [13] and hold it a few seconds until pointers of the galvanometers stops moving. Record this second current. Variation between these currents will give an approximate idea of the life expectancy of the picture tube.

For 10 division variations (e.g. from 1.00 to 0.80 mA), the life expectance will be less than 1 year.

For 5 division variations (e.g. from 1.00 to 0.90 mA), the life time may be about 1 year.

For variations between 2 and 3 divisions, the life time may be about 1 to 2 years.

If reading does not drop down, the tube may be assumed in good order, new or almost new.

The greater the difference between both readings and the faster the current drops, the less will be the life expectance of the picture tube will be less.

In a new tube, difference of current will be almost void.

f. G1 VARIABLE test

Push key G1 VARIABLE [20]. In this function, the G1 voltage depends on the control G1 VARIABLE [27] position, running from -100V to 0V. In this way a simultaneous plotting can be performed of the characteristic curve, voltage and current of the three cathodes in function of the G1 voltage.

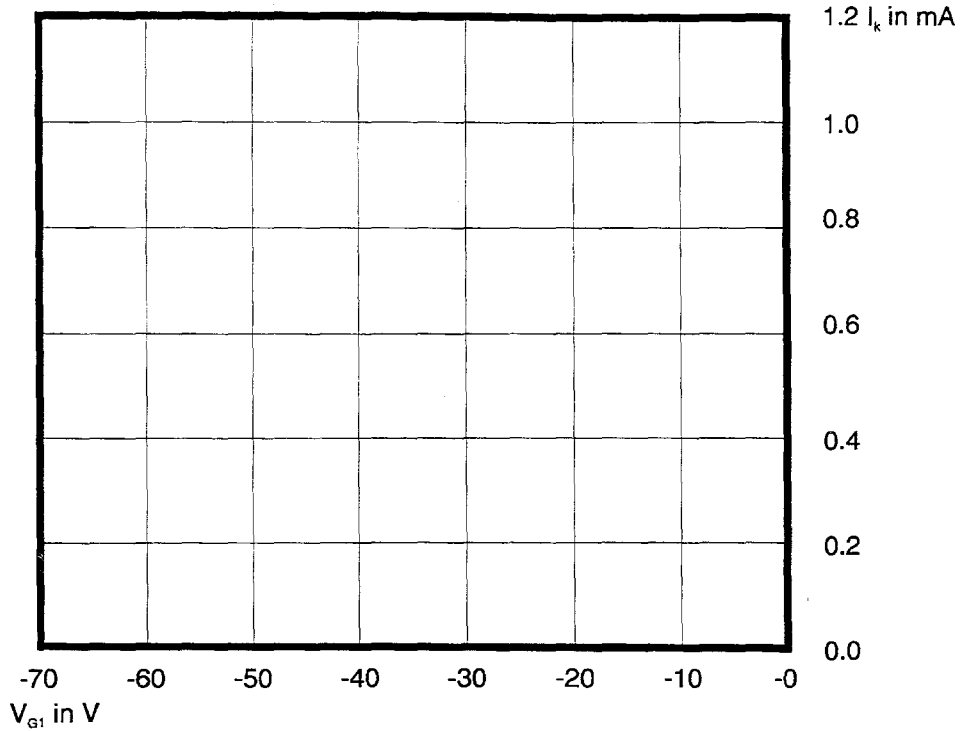

Example of a diagram to draw characteristic curve.

g. TRACKING test

Push key CUT-OFF [21]. Next push the COLOR TRACKING pushbutton [14] holding it the entire test time. The meter pointers will deflect to about the middle of the scale. Look at the meter that gives the highest reading among the three. Then turn controls [13] (COLOR TRACKING) of the two other meters clockwise (one by one) until they match the reading of the highest one. On achieving it, this means that difference of current between the three cathodes is contained within the admissible limits.

Otherwise, it means that difference of current of the lowest cathode(s) is greater than the admissible one; therefore, the tube is to be rejuvenated.

5. MAINTENANCE

5.1 General

Current maintenance by the user is limited to cleaning the instrument and replacing fuses.

All other maintaining, repairing and calibrating procedures should be performed by the B&K Precision repair department or licensed agents.

To pull out the chassis from the case open the item by removing the 6 panel screws.

6. SERVICE INFORMATION

Warranty Service: Please return the product in the original packaging with proof of purchase to the below address. Clearly state in writing the performance problem and return any leads, connectors and accessories that you are using with the device.

Non-Warranty Service: Return the product in the original packaging to the below address. Clearly state in writing the performance problem and return any leads, connectors and accessories that you are using with the device. Customers not on open account must include payment in the form of a money order or credit card. For the most current repair charges contact the factory before shipping the product.

Return all merchandise to B&K Precision Corp. with pre-paid shipping. The flat-rate repair charge includes return shipping to locations in North America. For overnight shipments and non-North America shipping fees contact B&K Precision Corp.

B&K Precision Corp.
1031 Segovia Circle
Placentia, CA 92870
Phone: 714-237-9220
Facsimile: 714-237-9214
Email: service@bkprecision.com
Website: www.bkprecision.com

Include with the instrument your complete return shipping address, contact name, phone number and description of problem.

BK PRECISION®

PN: 480-809-9-001
Printed in Spain

1031 Segovia Circle
Placentia, CA 92870-7137 USA
TEL: 714-237-9220
FAX: 714-237-9214
www.bkprecision.com